

$\phi 44.7H8$	+0.039	✓ / / 1.6 / /
	+0.000	
$\phi 62H8$	+0.046	✓ / / 1.6 / /
	+0.000	

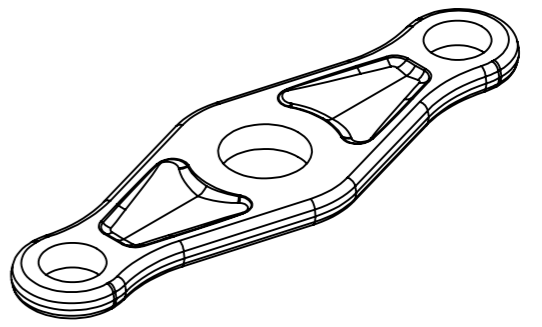

DEO ZA: Delovi kočionog sistema						Termička obrada:						
						Izdav.						
						Datum						
ISO 2768 - m DIN 8570 - BF						Razmera 1:2 Težina (kg) 5.3						
						DIN ISO1302						Materijal DIN EN 10025 1.0570 S355J2
A	1047	06.07.	P.Ž.	Crtao	06.07.	P.Živković	Naziv					
				Konstr.	06.07.	P.Živković	BALANSER 180-180S					
				Odobr.		N.Madžarević						
						Crtež br. Ž02.012.02.777.01 List 01						
						Br. otk. G-2-2543 Zamena za:						
St. i.	Izmene	Datum	Ime	veza sa:								

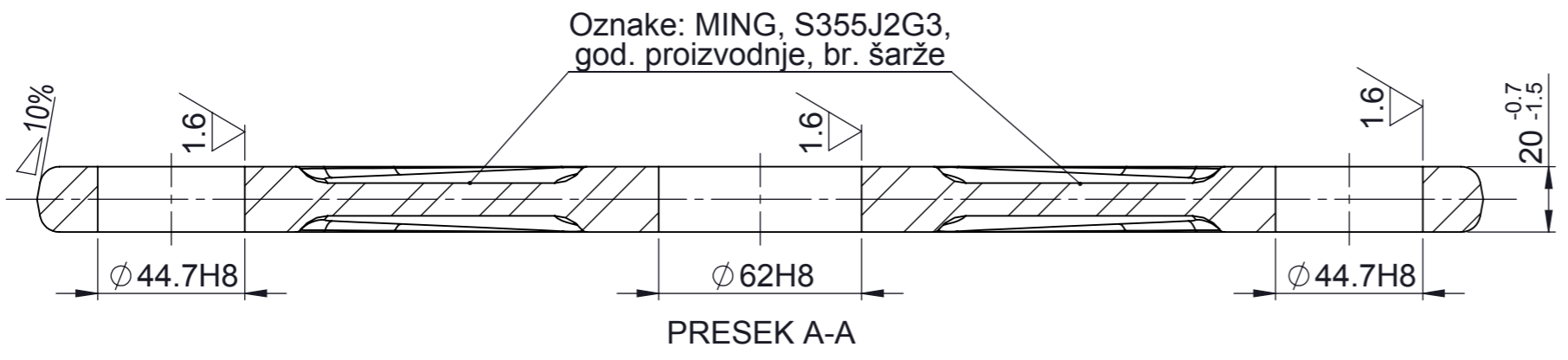
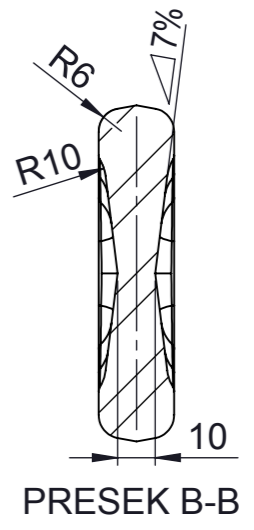