

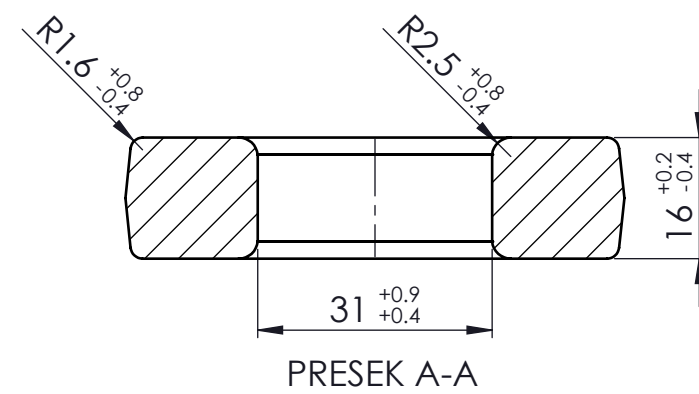

√ Rz63 (√ Rz40)

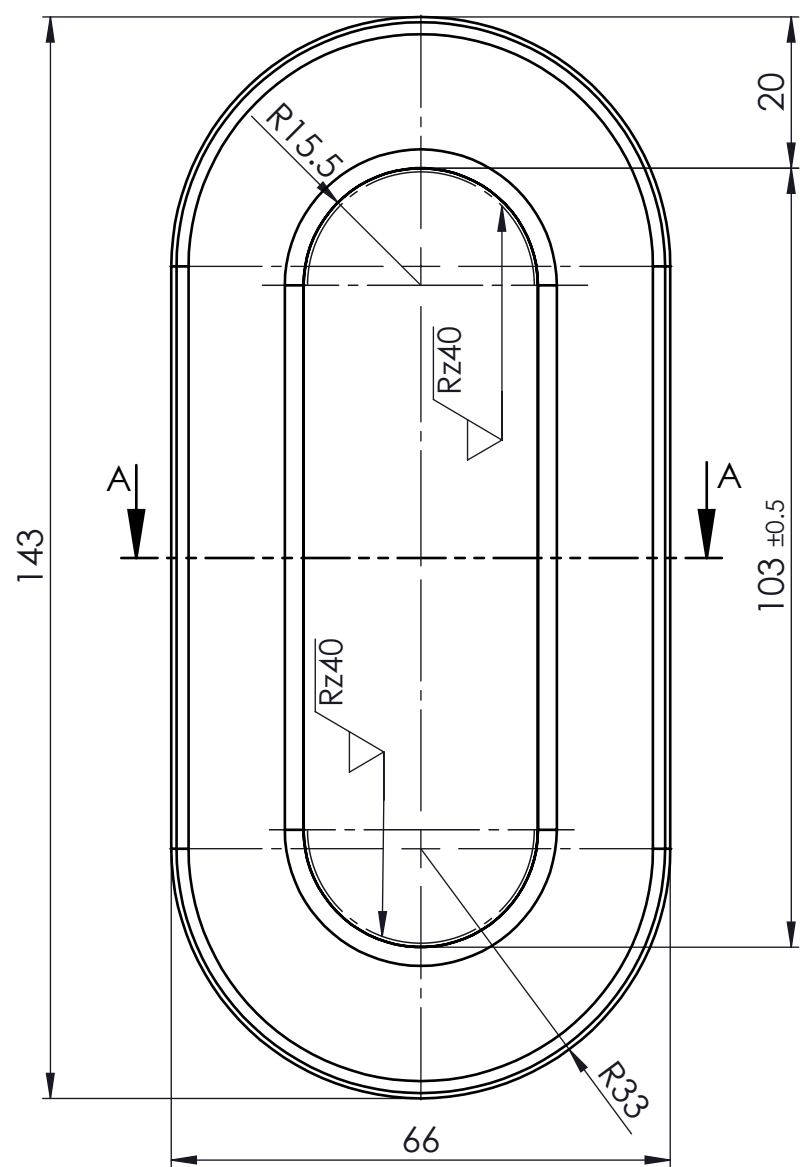

DEO ZA: Ram okretnog postolja Y25				Termička obrada:			
				Izdav.			
				Datum			
				Razmera 1:1		Težina (kg) 0,67	
				Materijal DIN EN 10025 1.0570 S355J2			
A	1004	10.12.	P.Ž.	Crtao 30.10.12.	P.Živković	Naziv	
				Konstr. 17.06.08.	I.Urošević	KARIKA 16 Link	
				Odobr. 10.12.	N.Madžarević		
						Crtež br. Ž02.010.01.777.03	
						List 01	
St. i.	Izmene	Datum	Ime	veza sa:3Fwg696.0.02.026.001	Br. otk. G-4-1572	Zamena za:	