

Ø 45H8	+0.039
	+0.000
	—

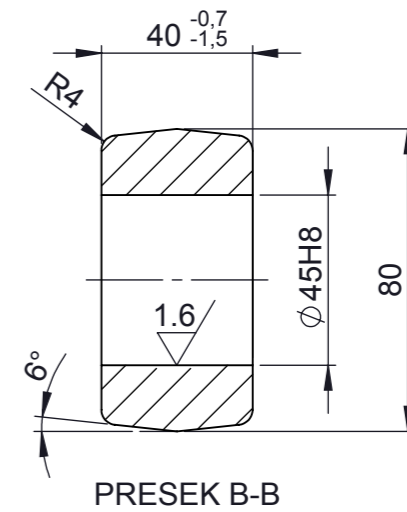

DEO ZA: Delovi kočionog sistema					Termička obrada:				
					Izdav.				
					Datum				
ISO 2768 - m DIN 8570 - BF					Razmera 1:2				
					Težina (kg) 4.85				
DIN ISO1302					Materijal DIN EN 10025 1.0570 S355J2				
					Naziv				
A	1054	06.09.	P.Ž.	Crtao	06.09.	P.Živković	FIKSNA TAČKA Fixed piece		
				Konstr.	06.09.	P.Živković			
				Odobr.		N.Madžarević			
St. i.					Crtež br. Ž02.012.10.777.01				
					List 01				
	Izmene	Datum	Ime	veza sa: E2240.04.27D1	Br. otk. G-2-0399	Zamena za:			

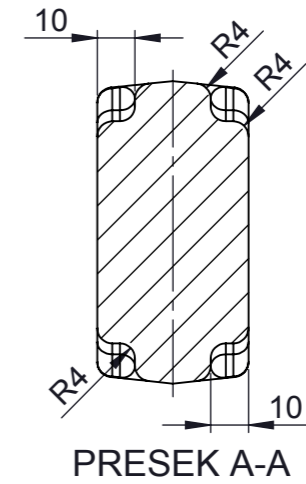