

Ø33H8	+0.039	
	+0.000	
—		

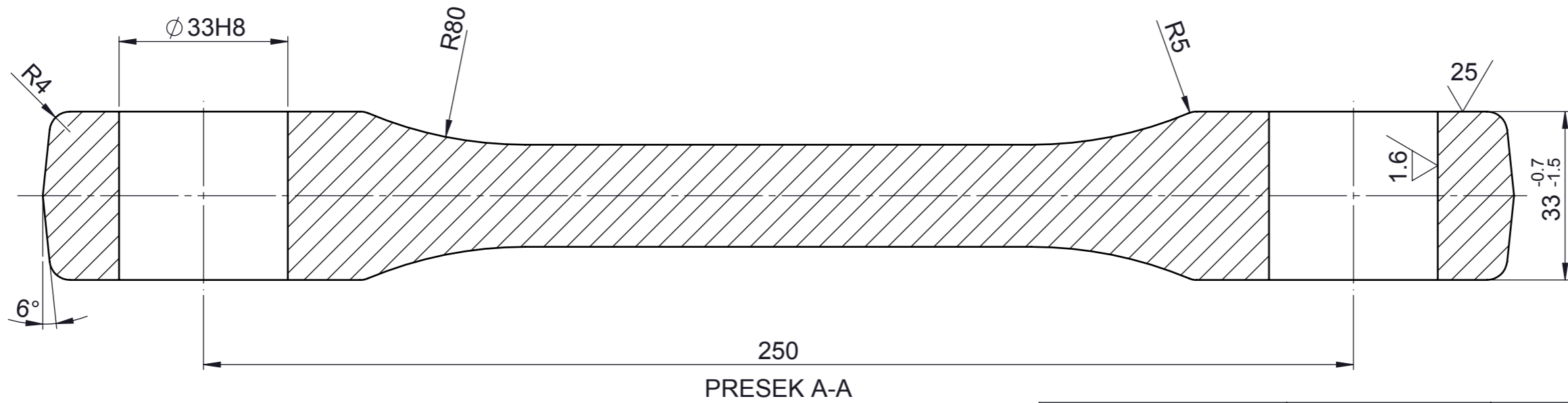

DEO ZA: Delovi kočionog sistema				Termička obrada:		
				Izdav.		
				Datum		
				Razmera	1:1	Težina (kg) 2.2
				Materijal	DIN EN 10025 1.0570 S355J2	
A	1041	06.07.	P.Ž.	Crtao	06.07.	P.Živković
				Konstr.	06.07.	P.Živković
				Odobr.		N.Madžarević
				Naziv VEŠALICA 250 Brake Block Hanger 250		
				Crtež br.		List
				Ž02.012.08.777.01		01
St. i.	Izmene	Datum	Ime	veza sa:3ELH600.0.07.043.061	Br. otk.	Zamena za:
					G-3-0384	

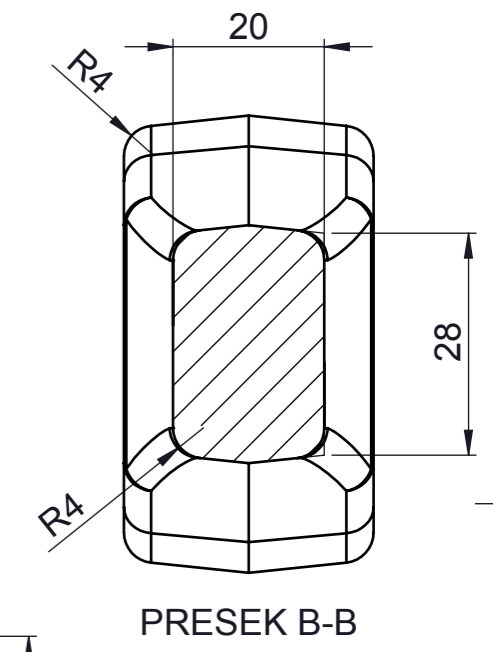
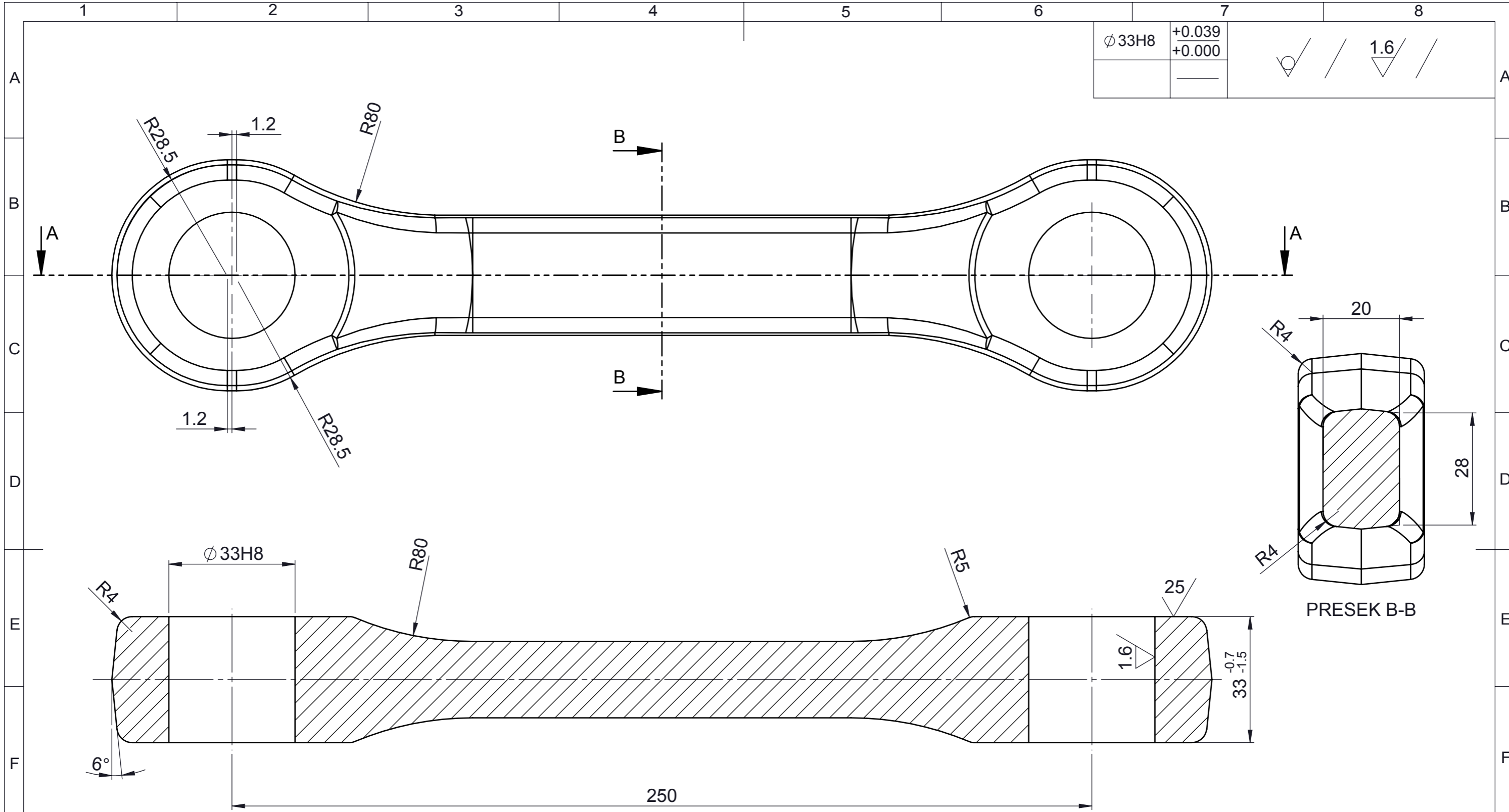