

Ø 50C11	+0.290	✓ (25 / 12.5 / 6.3)
	+0.130	

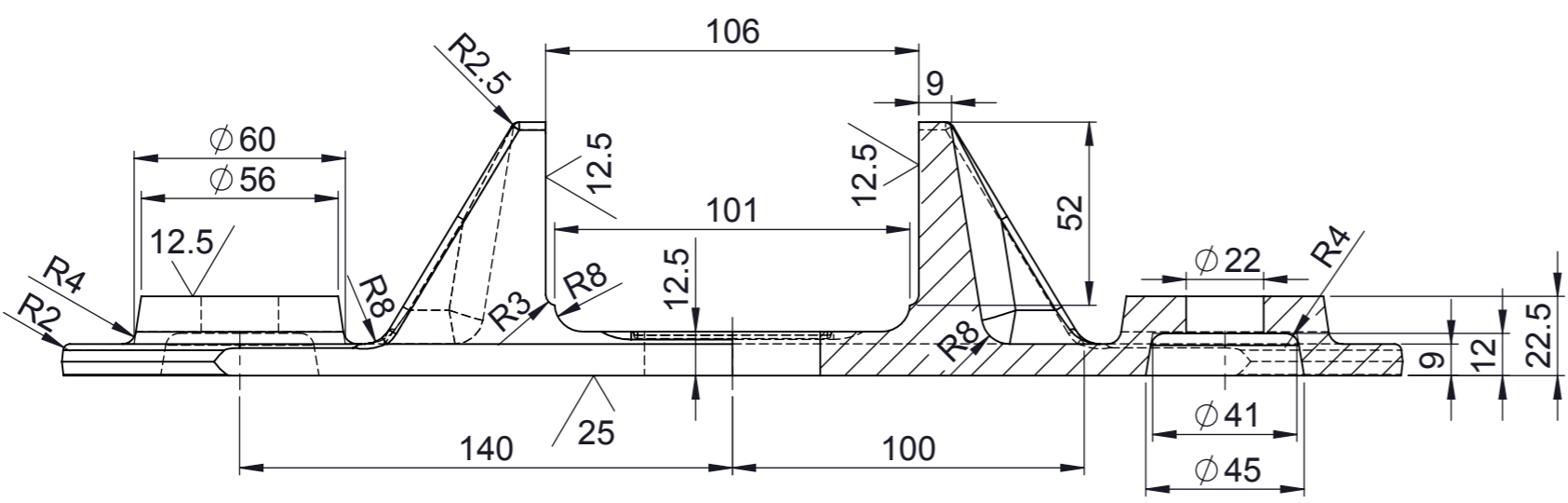

PRESEK A-A

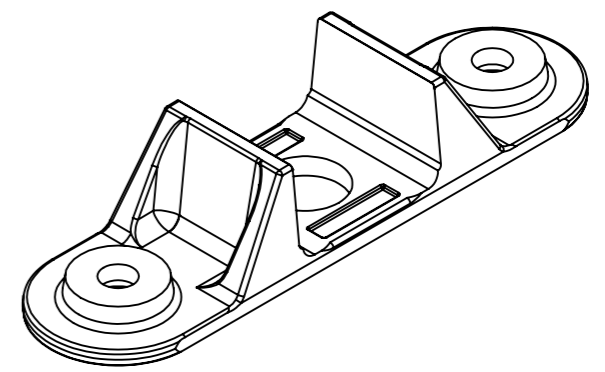
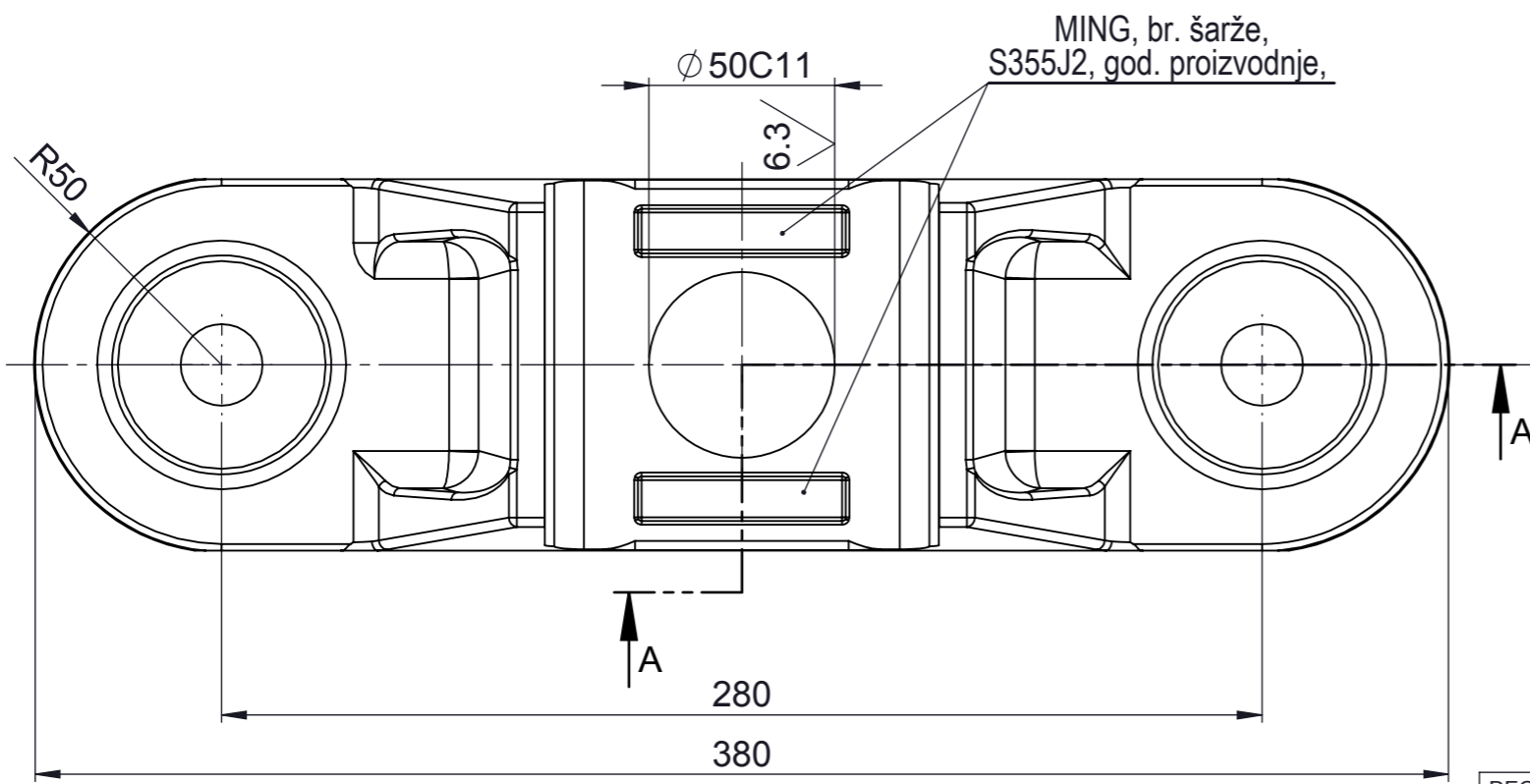
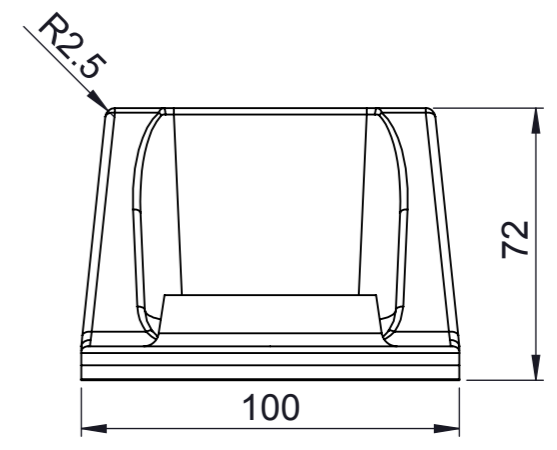

DEO ZA: Delovi gornjeg sklopa		Termička obrada:	
		Izdav.	
		Datum	
		Razmera	1:2
		Težina (kg)	4,65
		Materijal	DIN EN 10025 1.0570 S355J2
A	1030	08.07.	P.Ž.
		08.07.	P.Živković
			P.Živković
			N.Madžarević
		KLIZNICA Stand	
		Crtež br.	Ž02.011.02.777.01
		Br. otk.	G-2-1358
		Zamena za:	
St. i.	Izmene	Datum	Ime
			veza sa:3ELH600.0.04.082.021
		veza sa:	3ELH600.0.04.082.021
		Br. otk.	G-2-1358
		Zamena za:	
		Crtež br.	Ž02.011.02.777.01
		List	01
		L	

